



High Commission of the Independent State of Papua New Guinea
Wellington, New Zealand

Application for a Travel Document (Renewal)

(Passport Act of 1982)

* **Instructions:** Applications should be completed at least 3 weeks before applicant intends leaving Papua New Guinea.

- WHERE TO APPLY:** Applications for a Renewal of a PNG Travel Document (Passport) should be lodged with the Department of Foreign Affairs & Immigration, P.O BOX 422 WAIGANI NCD (Immigration and Citizenship Branch) EACH PERSON MUST COMPLETE A SEPARATE APPLICATION.
- FEE:** The fee for a new passport is K100.00
- COLLECTION OF PASSPORT:** Agents may not collect passports on behalf of clients. Your passport will be forwarded by registered post unless you elect to collect it personally.
- CHANGE OF NAME:** If you have changed your name please provide details of all previous names used.
- PREVIOUS TRAVEL DOCUMENTS:** You must attach your previous travel document unless it has been lost, stolen or destroyed.
- EVIDENCE OF CITIZENSHIP:** Your application should be accompanied by evidence of your citizenship. Attachment 'A' on page 4 should be completed in this respect. Your birth certificate or citizenship certificate, and in the case of married women your marriage certificate, should be submitted.
- CERTIFICATE REGARDING APPLICANT:** The certificate on page 3 in respect of every application must be completed. The following persons are authorised to furnish this certificate: Lawyers, Medical Practitioners, Magistrates, Ministers of Religion, Commissioner of Oaths, Commissioned Officers of the Defence Force and Police Force.

The person completing the certificates must have known the applicant for at least three years. It is essential that the person who signed the Certificate Regarding Applicant on page 3 should also endorsed the back of one photograph as follows:

'I certify this to be a genuine photograph of (name in full)', and sign.

- CONSENT OF PARENTS:** Applicants under 17 years of age must furnish the consent of their parents or legal guardians on page 2.
- PHOTOGRAPHS:** With your application you should submit two recent photographs. These should be head and shoulders only, taken 'Full Face' without had or tinted glasses and with a light coloured background. All photographs should be within the dimensions of 35mm x 45mm. It is essential that the person who signed the Certificate Regarding Applicant on page 3 should also endorse the back of one photograph as follows:

'I certify this to be a genuine photograph of (name in full)', and sign.

- DECLARATION:** The Declaration on page 3 must be signed by the applicant, or in the case of a child unable to sign, by the lodging parent or legal guardian.

11. SIGNATURE:

- The applicant must sign both of the small Signature labels using a ball-point pen. Please take care to stay within the borders marked.
- If the applicant is unable to sign, put a line through both of the small signature labels.

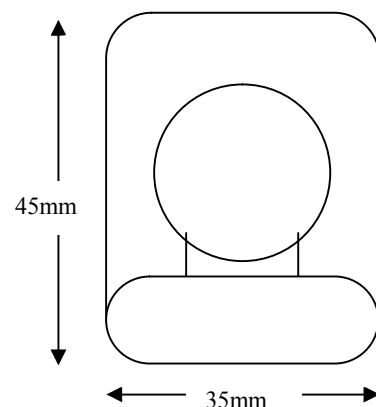

UNABLE TO SIGN

SIGNATURE LABEL

1. Type of Travel Document

Standard Passport Official Passport Certificate of Identity

Diplomatic Passport Emergency Travel Document

2. Applicant's Name

Family name Given names

3. Sex

Male Female

4. Has Applicant ever changed his/her name?

Yes No If Yes, state previous names here

5. Birth Place and Date

Village Town Province Country Date of birth / /

6. Personal Particulars

Height cm Colour of hair Colour of eyes Visual distinguishing marks

7. Marital Status *(tick whichever applies)*

Single Married Widow Divorced If Married, name of husband/wife

8. Address and Telephone

Residential Telephone

Correspondence Telephone

If Applicant is under 17 years of age, please provide consent to the application

9. Consent of Lodging Parent or Legal Guardian

I, _____ the father /mother / legal guardian (delete whichever not applicable) hereby give my consent to the applicant above being issued with a passport.

(First name) (Family name)

Signed Date Signature of Witness Date

Consent of Other Parent or legal Guardian

I, _____ the father /mother / legal guardian (delete whichever not applicable) hereby give my consent to the applicant above being issued with a passport.

(First name) (Family name)

Signed Date Signature of Witness Date

10. Proposed Departure Details

Vessel or Airline Port or Airport Countries proposed to visit Date

11. Has applicant previously been issued with a Papua New Guinea Travel Document

Yes No Travel Document number Issue Date Expiry Date

Bearer's name at time of issue

12. This previous Travel Document:

Is attached Has been lost Has been stolen Has been destroyed Has been damaged

Explain circumstances of loss/theft/other

Has the loss been reported to the police?

Yes No

If Yes, to which police officer or police station was the report made?

Date of report
/ /

13. CERTIFICATE REGARDING APPLICANT

Warning: Persons who, in support of an applicant for a passport, make any false statements either orally or in writing render themselves liable to a fine of K400.00 or imprisonment for six months.

I, _____
Name *Occupation*

of _____
Address *Telephone*

hereby declare that I have known personally the applicant _____
Applicant's name

for a period of more than 3 years and that the signature and photographs on or accompanying the application are those of the applicant, to the best of my knowledge and belief the statement made by the applicant in this form are true. On the same basis, I have endorsed the back of the applicant's photograph.
No fee has been charged for this certificate.

Signature

Date
/ /

14. DECLARATION

I, _____
declare that the statements made in this application are true and correct in every particular.

Dated this _____ day
of _____ 200

Signature or Mark

15. Applicants who cannot read or write English

The above declaration has been read/interpreted and explained by me in _____
language to the applicant in the presence of _____
and the applicant appeared to understand and approve of them.

Signature

Signature of witness

Full name

Full name

Occupation

Occupation

Address
Telephone number Date

Address
Telephone number Date

EVIDENCE OF CITIZENSHIP

Attachment A

Full name of mother

Place of birth of mother

Full name of father

Place of birth of father

Full name of mother's parents

Place of birth of mother's parents

Full name of father's parents

Place of birth of father's parents

Have you lived all your life in Papua New Guinea?

Yes No

If No, where?

Are you are citizen of Papua New Guinea?

Yes No

Are you a citizen of a foreign country?

Yes No

If Yes, which country?

Supplementary Information



**High Commission of the Independent State of Papua New Guinea
Wellington, New Zealand**

Requirements to renew a PNG Travel Document (Passport)

Please provide the following:

1. One application form for a "Travel Document" (Renewal)
2. Two passport size photographs of the applicant
3. Renewal fee of NZ\$40.00
4. Return postage (courier pack) or NZ\$5.00 (for postage within NZ) or NZ\$10.00 (for international postage)
5. Any supporting documents

Please forward your application form to PNG High Commission in Wellington for processing.

Requirements for a new PNG Travel Document (Passport)

This application must be lodged at the Immigration and Citizen Division Department of Foreign Affairs and Immigration in WAIGANI NCD, Papua New Guinea (P.O BOX 422 WAIGANI NCD).

6. One application form for a "Travel Document"
7. Two passport size photographs of the applicant
8. Renewal fee of PGK100.00 (bank draft made out to the Department of Foreign Affairs and Immigration is recommended)
9. Return postage (courier pack) or PGK10.00 (international postage)
10. Any supporting document

Please contact the High Commission if you have any enquiries.